

10W Weatherproof EWIS Horn Speaker

HORN-C2053



Features

- Weather resistant
- UV stabilised ABS construction
- Superb speech & music reproduction
- Excellent sound dispersion 3 EWIS line monitoring system compatible
- Compatible with C 2052 Wurli-Gig™ Speed Fixing Bracket
- 5 year warrant

Application

The C 2053 has been engineered to meet the stringent requirements of AS1670.4. Its high efficiency, high SPL output provides excellent speech reproduction and sound distribution for both general PA and emergency evacuation use.

Compact yet very efficient with a high SPL of 104dB, 1W @ 1m. This horn speaker is ideal for car parks, plant rooms, industrial plants, schools, train/bus stations and airports etc.

To reduce installation time, use the C 2052 Wurli-Gig Speed Fixing Bracket.

Installation

It is supplied with an in-built bipolar capacitor making it compatible with EWIS control systems employing line monitoring circuitry. It is also fitted with a 4 core termination lead to provide connection points for loop in, loop out wiring, as required by Australian Standards.

A screwdriver adjustable switch is provided to select the desired power tapping. Supplied with nickel plated chrome hardware.

The neutral grey RAL colour of C 2053 provides an architecturally unobtrusive finish to virtually any installation.

C 2052 Wurli-Gig™ Speed Fixing Bracket

A world first in horn speaker mounting, the Wurli-Gig Speed Fixer saves 5 to 10 minutes installation, saving installers around \$10 in labour - per horn speaker. Normal horn speaker installation requires removing the mounting 'U' bracket, which is then fixed to the wall and reassembled. This is very time consuming - especially when some installations can require 100's of horns.

The Wurli-Gig Speed Fixer mounts to the wall and the horn speaker snap fits to the bracket instantly. To prevent theft, security screws can be fitted if required. The Wurli-Gig Speed Fixer suits the C 2053 speaker and has been engineered & manufactured in Australia.



10W Weatherproof EWIS Horn Speaker

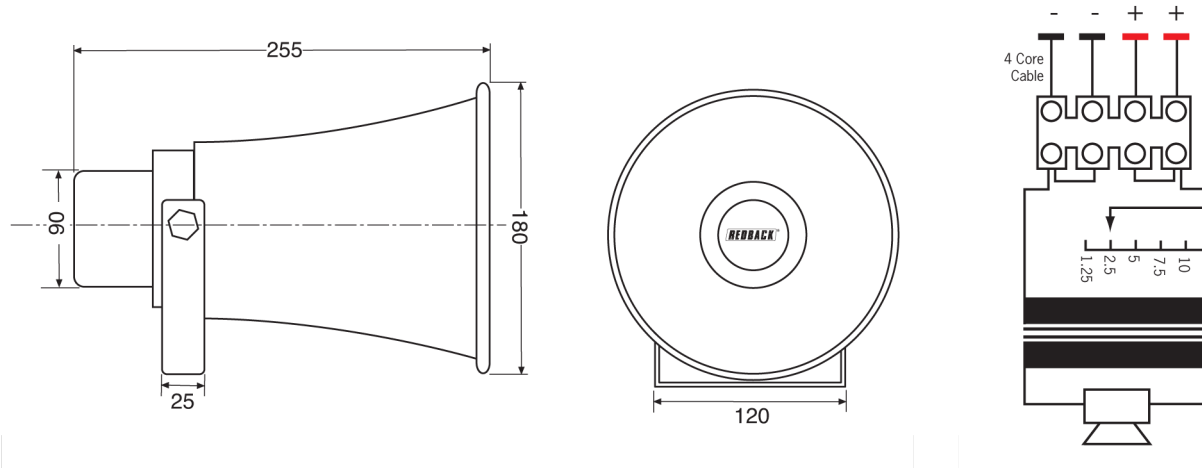

Specifications

Electrical

Power taps:	1.25, 2.5, 5, 7.5, 10W
SPL 1W @ 1m:	104dB @ 1kHz (+/- 2dB)
SPL Max Tap @ 1m:	114dB @ 1kHz (+/- 2dB)
Frequency response:	340Hz-10kHz
Connection:	4 core fly lead
EWIS line monitoring:	22uF bipolar capacitor fitted
Dispersion angle:	110°

Mechanical

Driver construction:	Aluminium voice coil former
Mounting depth:	275mm
Overall weight:	1.8kg

Environmental

Operating temperature:	-20°C to +55°C
Relative humidity:	< 95%

Accessories

C 2052 Wurli-Gig™ speed fixing wall bracket.

Frequency Response (SPL 1W @ 1m)

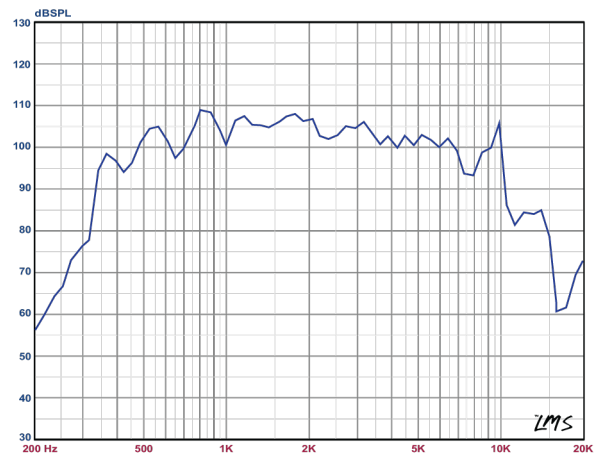

Polar Plot (SPL vs Angle)

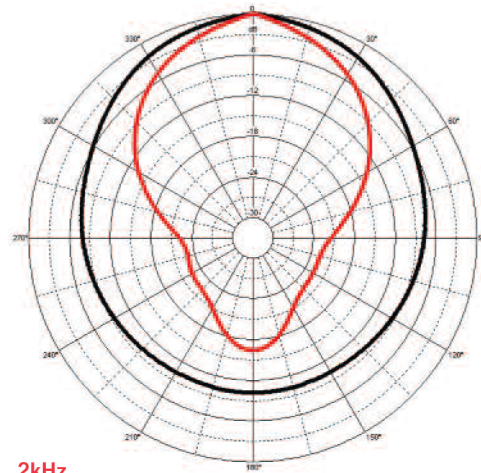

Architectural Specifications

The horn speaker shall operate at 100V and have power taps of 10W, 7.5W, 5W, 2.5W and 1.25W. Power settings shall be made by screw driver switch. It shall have SPL of 104 – 114dB. It shall have a frequency response of 340Hz to 10 kHz and a dispersion angle of 110°. It shall have a 22uF bipolar isolation capacitor for line monitoring. The horn will be provided with a four core cable for field wiring connection. Two for the incoming circuit and two for the outgoing circuit.

The speaker body shall be made of ABS and have an IP66 rating. The speaker shall incorporate nickel plated chrom hardware and steel mounting bracket. The horn speaker shall be a REDBACK model C 2053.